

# INSTALLATION & USER INSTRUCTIONS

## WALL MOUNTED ELECTRIC FIRE

SUPERIORFIRES

Superior Fires  
Christchurch, Dorset BH23 2BT  
Tel: 01202 588 632  
Fax: 01202 499326  
[www.superiorfires.co.uk](http://www.superiorfires.co.uk)  
Email : [sales@superiorfires.co.uk](mailto:sales@superiorfires.co.uk)

### MODELS COVERED BY THESE INSTRUCTIONS

EF11-36  
LED GRAND ELECTRIC



### LED GRAND ELECTRIC FIRE

Please note: Except where otherwise stated, all rights, including copyright in the text, images and layout of this booklet is owned by Focal Point Fires plc. You are not permitted to copy or adapt any of the content without the prior written permission of Focal Point Fires plc.

**All instructions must be handed to the user for safekeeping.**

Revision A- 05/16

Section	Contents	Page No.	Section	Contents	Page No.
1.0	Important Notes	2	8.0	Installation Wall Mounted	5
2.0	Installation Requirements	3	9.0	Operating the Appliance	8
3.0	Appliance Data	3	10.0	Safety Cutout System	11
4.0	Fixing Kit Checklist	3	11.0	Cleaning and Maintenance	11
5.0	Component Checklist	3	12.0	Servicing	11
6.0	Site Requirements	4	13.0	Troubleshooting Guide	12
7.0	Clearances to Combustibles	4	14.0	Guarantee - Terms and Conditions	12

## 1.0 IMPORTANT NOTES

### IMPORTANT - THESE INSTRUCTIONS SHOULD BE READ CAREFULLY AND RETAINED FOR FUTURE REFERENCE.

When using this electrical appliance, basic precautions should be followed to reduce the risk of fire, electric shock and injury to person, including the following:

- This heater must be used on an AC supply only and the voltage marked on the heater's rating label must correspond to the supply voltage.
- **DO NOT** switch the appliance on until it is properly installed as described in this manual.
- This appliance can be used by children aged from 8 years and above and persons with reduced physical, sensory or mental capabilities or lack of experience and knowledge if they have been given supervision or instruction concerning use of the appliance in a safe way and understand the hazards involved. Children shall not play with the appliance. Cleaning and user maintenance shall not be made by children without supervision.
- Children of less than 3 years should be kept away unless continuously supervised. Children aged from 3 years and less than 8 years shall only switch on/off the appliance provided that it has been placed or installed in its intended normal operating position and they have been given supervision or instruction concerning use of the appliance in a safe way and understand the hazards involved. Children aged from 3 years and less than 8 years shall not plug in, regulate and clean the appliance or perform user maintenance.
- **CAUTION:** Some parts of this product can become very hot and cause burns. Particular attention has to be given where children and vulnerable people are present.
- If the supply cord is damaged, it must be replaced by the manufacturer, its service agent or similarly qualified persons in order to avoid a hazard.
- The heater must not be located immediately below a socket-outlet.
- **DO NOT** use this heater in the immediate surroundings of a bath, a shower or a swimming pool.



- **WARNING:** In order to avoid overheating, do not cover the heater.
- **DO NOT** use this heater with a programmer, timer, separate remote-control system or any other device that switches the heater on automatically, since a fire risk exists if the heater is covered or positioned incorrectly.
- **CAUTION:** In order to avoid a hazard due to inadvertent resetting of the thermal cutout, this appliance must not be supplied through an external switching device, such as a timer, or connected to a circuit that is regularly switched on and off by the utility.
- Keep furniture, curtains and other fabric material away from the appliance.
- **DO NOT** leave the appliance unattended during use.
- From time to time, check the cord for damage. Never use the appliance if the cord or any part of the appliance shows signs of damage.
- **DO NOT** run the mains cable under carpets, rugs etc.

## 1.0 IMPORTANT NOTES - CONTINUED

GB IE

- **DO NOT** cover or obstruct the heater in any way. Overheating will result if it is accidentally covered.
- Never immerse the product in water or any other liquids.
- **DO NOT** use the appliance outdoors.
- Before cleaning the appliance, ensure it is unplugged from the power and that it is completely cool.
- **DO NOT** clean the appliance with abrasive chemicals.
- Never use accessories that are not recommended or supplied by the manufacturer. It could cause danger to the user or damage to the appliance.
- **DO NOT** insert or allow foreign objects to enter the inlet or outlet vents as this may result in electric shock, fire or damage to the appliance.
- **DO NOT** install the fire using an extension cord.
- Unplug from the mains supply if the appliance is not to be used for long periods.
- For installation and maintenance details refer to page 5-9.

## 2.0 INSTALLATION REQUIREMENTS

The appliance is supplied with a pre-wired three pin plug (13 Amp fuse rated) and 1.8 metres of electrical cable. It is therefore necessary for a suitable electrical socket to be located within this distance and be easily accessible. This appliance is designed to be wall hung, using the wall fixtures/fixings provided. **DO NOT** recess any part of appliance into the wall. This appliance is suitable for installation in static holiday/park homes.

## 3.0 APPLIANCE DATA

Supply Voltage and rating power : 220-240V ~AC 50Hz, 1260-1500W  
Heating Elements : 1260-1500W  
Location : Indoor use only

Fuse Rating : 13 Amp  
Lighting : LED  
Supply plug/cord : BS1363/1.8 metres length

This fire is fitted with LED's (Light Emitting Diode) in place of conventional bulbs. LED's generate the same light levels as conventional bulbs, but use a fraction of the energy consumed. LED's are maintenance free and will not require replacing during the life of the product.

## 4.0 FIXING KIT CHECKLIST

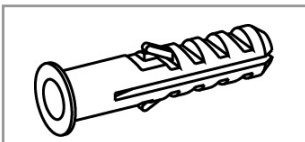

1. Large Wall Anchor x 5

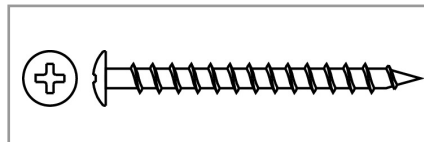

2. M5 x 50mm Screw x 5

## 5.0 COMPONENT CHECKLIST

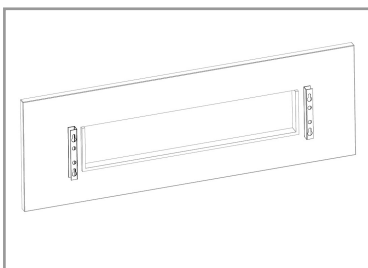

1. Stone Fascia

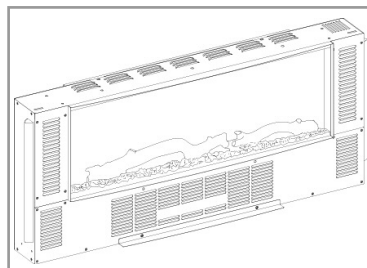

2. Firebox

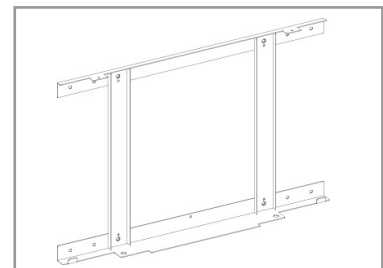

3. Mounting Bracket

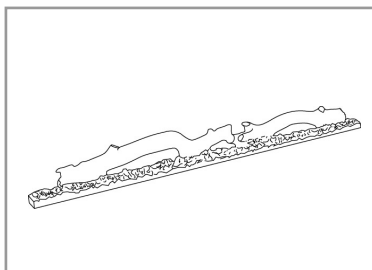

4. Logs

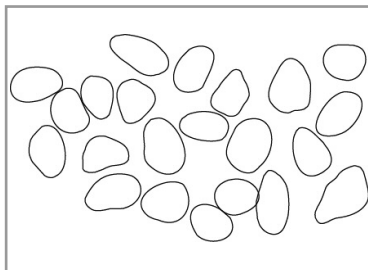

5. Pebbles Dependent On Model

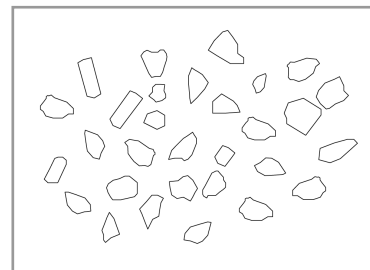

6. Crystals

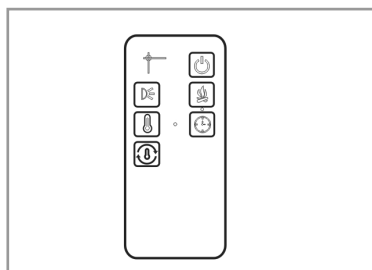

7. Remote Control

## 6.0 SITE REQUIREMENTS

It should be noted that the appliance creates warm convected air currents. These currents move heat from the room surroundings to, and up the wall surfaces adjacent to the heater.

Installing the heater next to these types of wall coverings or operating the heater where impurities in the air, (such as tobacco smoke) exist, may slightly discolour wall finishing.

If the appliance is to be mounted on a dry lined or timber framed construction then the integrity and ability of the wall to carry the weight of the appliance must be confirmed. It is important in these circumstances that any vapour barrier and/or structural members of the house frame are not damaged.

If you are unsure of the ability of the wall to carry the weight and/or which type of wall fixing to use, you should take professional advice and obtain the correct fixings. Alternatively, find a more suitable wall location.

### DO NOT

- mount on a ceiling or floor
- recess any part of the appliance into the wall, or run the supply cable under carpets
- site any electrical equipment e.g. plasma screen TV sets etc, on the wall below the appliance.
- site in a position where curtains or drapes could cover the appliance, or other soft materials could cover e.g. below a coat rack
- site behind an opening door where mechanical impact/damage could occur
- site where the supply cable would become a trip hazard
- sit, stand or forcefully pull on the appliance
- obstruct, cover or force items into the openings
- use the heater to dry clothes
- site/use in an outdoor location(s)

## 7.0 CLEARANCES TO COMBUSTIBLE MATERIALS

It is important that the following clearances are maintained from the appliance to combustible materials. These clearances are dependent on the mounting location as defined below:

- The minimum distance from the top of the appliance to a ceiling is 300mm
- The minimum distance from the bottom of the appliance to the floor is 200mm
- The minimum distance to the sides of the appliance is 100mm
- The minimum distance to the front of the appliance is 500mm

**CAUTION: DO NOT CONNECT THE APPLIANCE TO THE ELECTRICAL SUPPLY AT THIS TIME.**

Focal Point Fires plc. assumes absolutely no responsibility for injuries and damages that may occur due to improper installation or handling.

Remove any protective film coatings from the finished/decorative surfaces of the appliance, if any. After having selected the final mounting position of the appliance taking into account the integrity of the wall the firebox of the appliance may be secured to the wall.

To ensure customer safety, be sure to design the installation so that the strength of both the wall and any wall fixings used are sufficient. The appliance should not be installed until all wet plastering and/or dry wall sanding and wall painting has been completed. Do not block the ventilation holes of the appliance. The wall onto which the appliance is installed must be flat. Install only on a vertical surface. Avoid sloped surfaces. Installation onto anything other than a vertical wall may result in fire, damage or injury.

If the appliance is to be mounted on the inner leaf of a conventional cavity brick wall, or a solid wall, then the wall plugs and fixing screws provided may be used. Depending on the condition of the wall it may be necessary to use additional fixings. In this situation, any additional fixings and wall plugs should be of the same size and type as the ones provided.

If the appliance is to be mounted on a dry lined wall or a timber framed construction wall then efforts should be made to fix in at least two positions vertically, into one of the wooden studs, or supporting wooden members of the wall using two of the fixing screws provided. If this is not achievable then the wall should be strengthened using appropriate building materials.

**WARNING**

The wall where the appliance is to be installed must be capable of long-term support of the total load of the appliance. Measures should also be taken to ensure sufficient strength to withstand the force of earthquakes, vibration and other external forces. Plasterboard alone is not considered to be a structural material. It is not recommended to rely on plasterboard fixings alone to support the weight of the appliance.

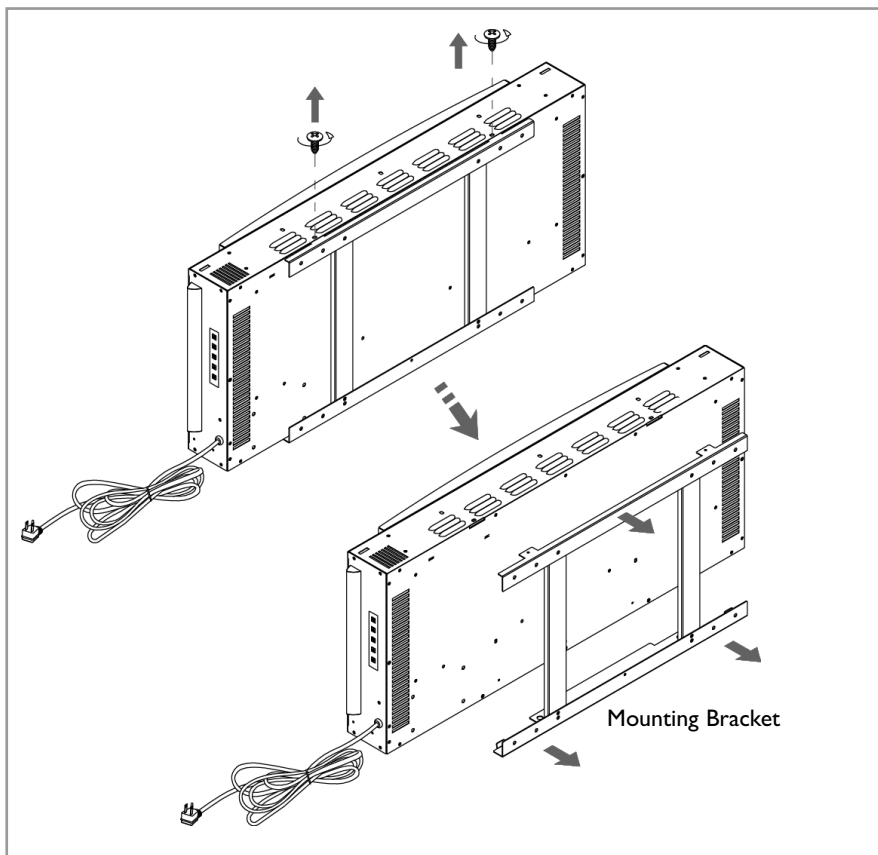
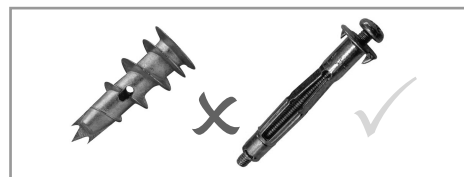

1. Unpack the unit and confirm that you have all the hardware and required parts.
2. Remove the mounting bracket from the firebox by unscrewing the two screws that secure the mounting bracket to the top of the firebox, using a phillips screwdriver. As shown above.

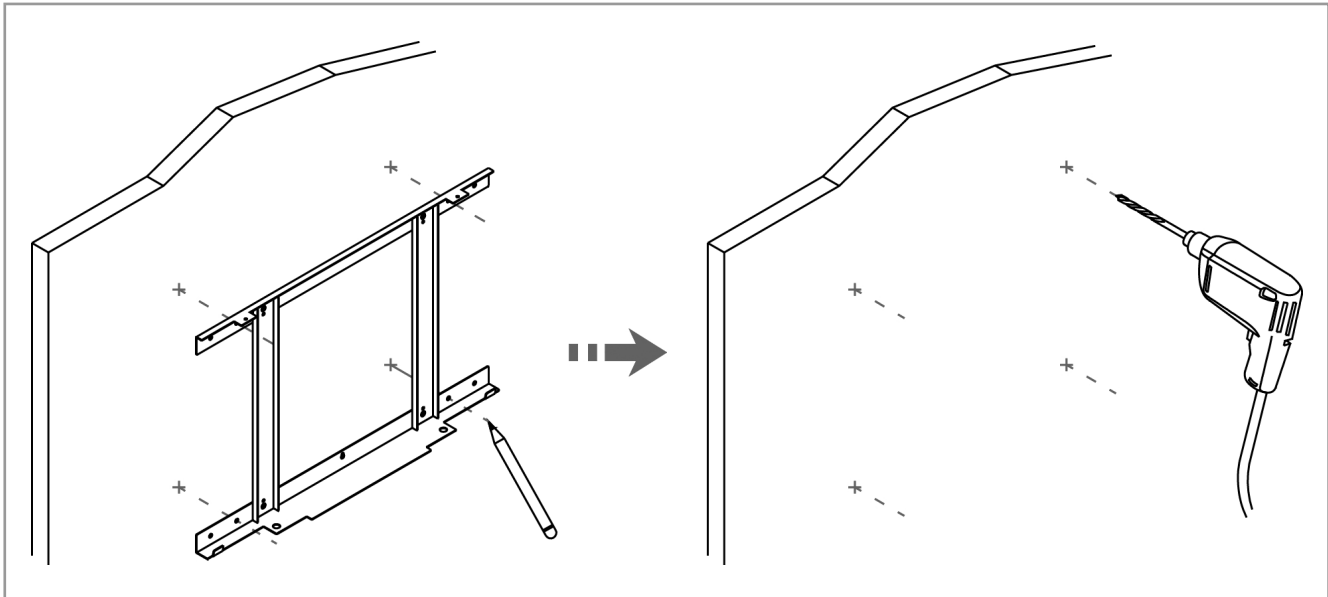

3. Find the optimal place to mount your wall-mounted Fire. Consider the proper position relative to your room, placement of furniture and windows.

4. Hold the mounting bracket up to the wall to verify the correct location and ensure that the mounting bracket is level. Use a pencil to mark the four mounting holes on the wall at the desired mounting location, using the mounting bracket as a template.

5. With an electric drill (not included) on its low setting, drill 5/16 inch diameter holes to at least 1 1/2 inch deep on the marked points. **NOTE:** If installing the mounting bracket to a wall stud, there is no need to drill the holes in the wood and no need for the plastic wall anchors. It is recommended to install the mounting bracket to at least one wooden stud.

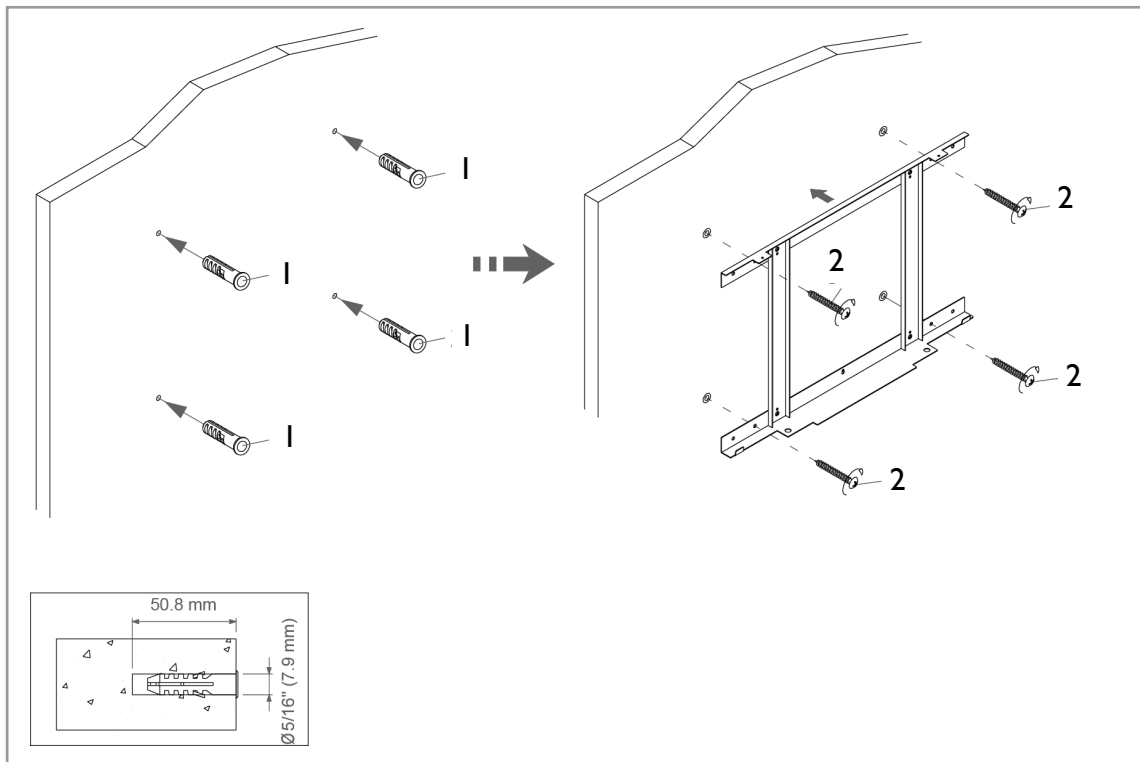

6. Tap 4 large wall anchors (1) into the pre-drilled holes with a hammer until they are flush with the wall.

7. Secure the mounting bracket to the wall by using four M5 x 50 mm screws (2). As shown.

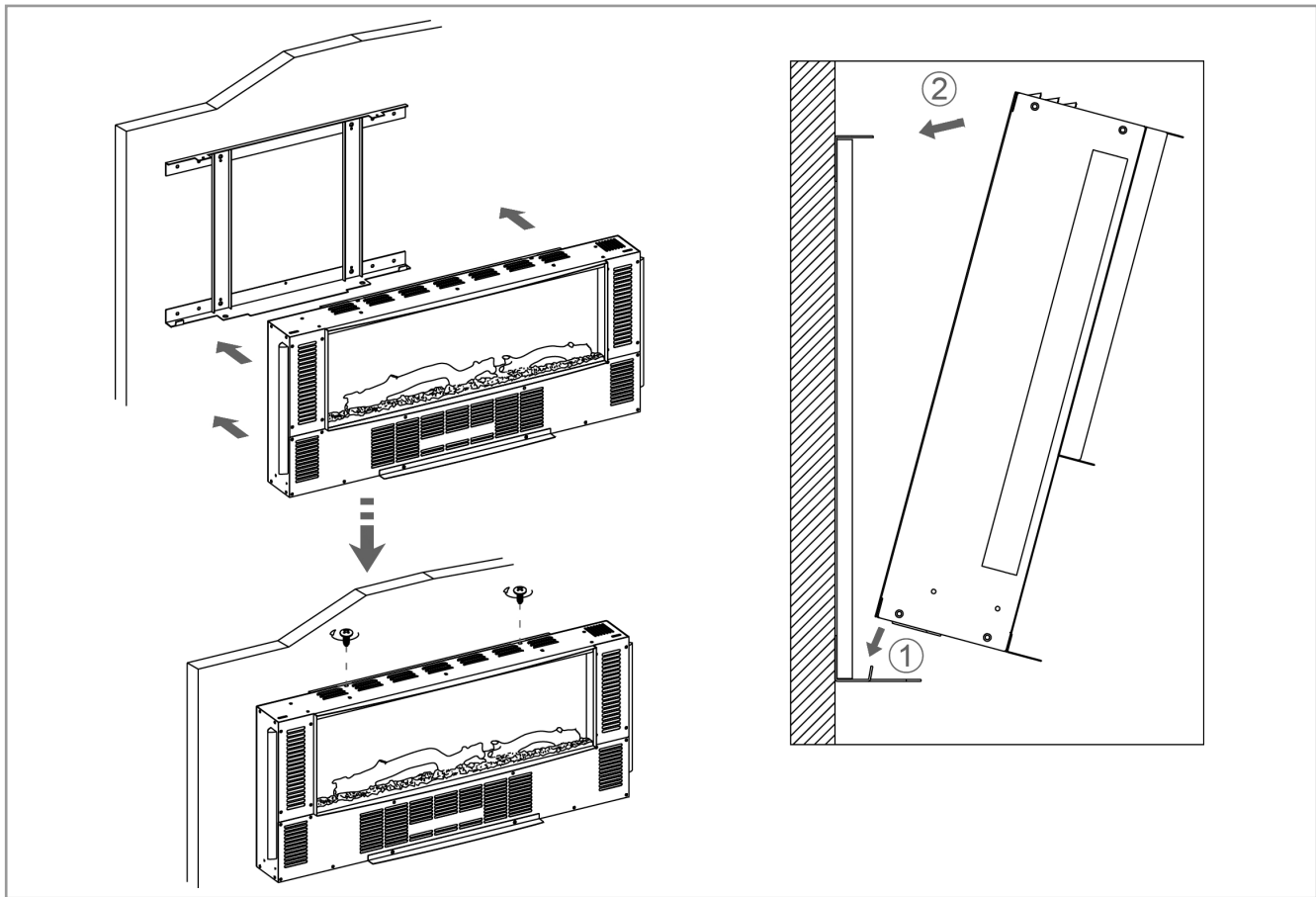

8. Hang the firebox on the hooks at the bottom of the mounting bracket, and push the top of the firebox into the mounting bracket. As shown.

9. Ask a friend to hold the electric firebox into place and secure it to the mounting bracket by refitting the two small screws which were removed in step 2. As shown.

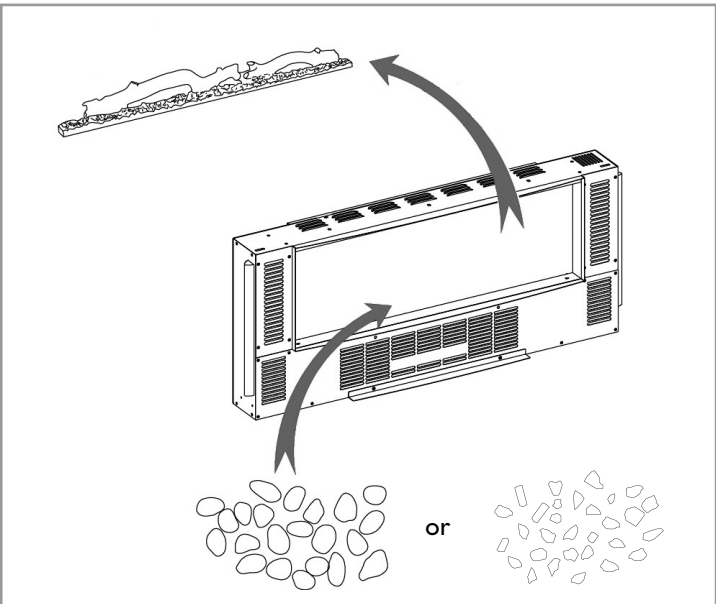

**NOTE:** We provided the optional pebbles and crystals for the fuel bed holder. To change the fuel bed follow the following steps below.

10. Remove the log set from the insert window ledge at the front of the firebox. As shown.

11. Arrange the pebbles or crystals on top of the fuel bed holder.

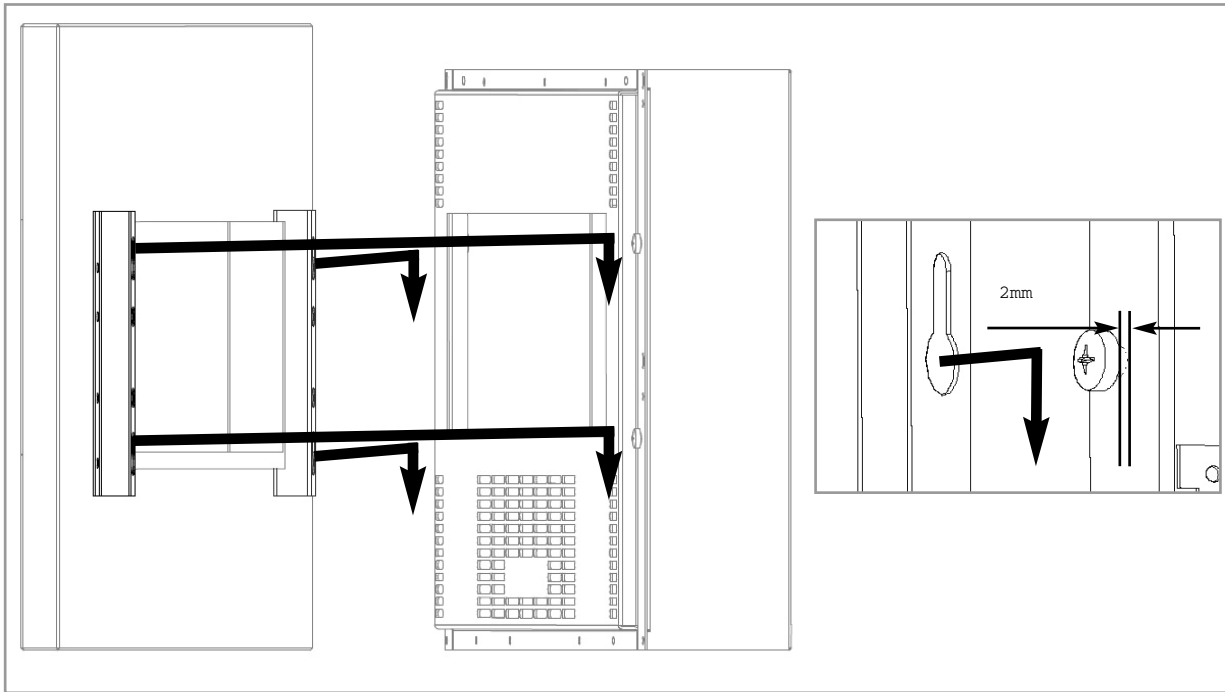

Ensure all/any protective film is removed as the fascia may be damaged if the fire is lit with the fascia in position whilst still covered in film.

12. Remove the fascia panel from any protective packaging. The fascia panel is supported by four M6 screws which protrude from the front of the outer casing. Ensure each screw is unscrewed approximately one turn from the fully screwed in position in order to create a 2mm gap as shown. Simply hang the fascia panel onto the outer casing ensuring that the corresponding keyhole shaped holes engage the screwheads fully.

**NOTE:** It is recommended that you use two people at this stage to prevent damaging the stone fascia or the firebox.

## 9.0 OPERATING THE APPLIANCE

On the top right side plate of the firebox is the control panel. This panel contains the buttons to properly operate the electric fireplace. The buttons on the control panel on the side of the firebox and the remote control function in the same way. The remote control has an effective range of up to 13 feet.

1. Main Power Button
2. Flames Control Button
3. Timer Function Button
4. Side Light Control Button
5. Thermostat On/Off Button
6. Thermostat Control Button (for remote control only)

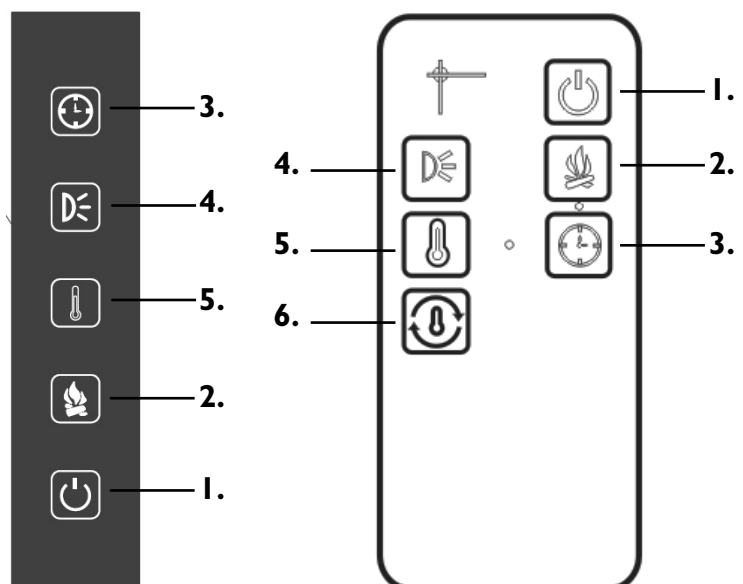



### Remote Control

The fire is supplied with an IR multifunction remote.

Before the remote will operate the plastic insulating sheet needs to be removed.

### Battery Replacement

Battery Requirements: CR2025

1. Locate and remove the battery bracket.
2. The battery has two sides, one with a button feature, and the other is flat.
3. Insert the battery with the button side down into the battery bracket, making sure the battery is firmly seated.

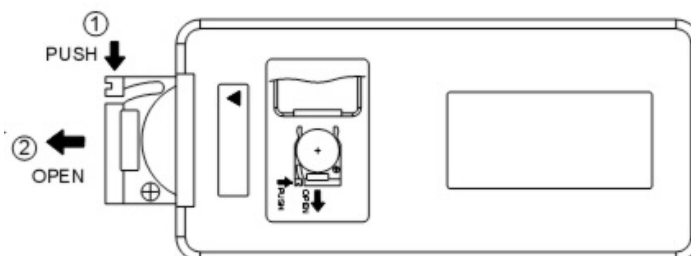

### Using The Main Power Button

The main power button (1) is located on the control panel on the right side of the electric fireplace. Pressing the main power button (1) once turns the power on.

Pressing the main power button (1) again will turn the power off.

If you find that none of the other buttons appear to work, check to make sure that the main power (1) is turned on.

### Battery Disposal

Battery must be recycled or disposed of properly. Check with your Local Authority or Retailer for recycling advice in your area.

### Using the Flames Control Button

Press the flames control button (2) to turn on the ember bed and flame effect.

Pressing the flames control button (2) once turns flames on and lights the ember bed.

Pressing the flames control button (2) again will cycle through different colours of the ember bed. The colour rotation mode will cycle through the 3 different colour settings continuously. When using Remote Control, you need to press the button (2) to enter the colour rotation mode. Reference the table for more detailed information.

Button Press	Flame State	Ember Bed Color
1 <sup>st</sup> press	ON	Amber
2 <sup>nd</sup> press	ON	Blue
3 <sup>rd</sup> press	ON	Amber and Blue
4 <sup>th</sup> press	ON	Color Rotation

### Using the Heater Control Button

The heater control button (5) turns the heater on and off. With the unit ON, press the control panel heater button (6) for 5 seconds and enter temperature adjustment mode.

Hold button (2) down for ten seconds to change from Fahrenheit to Celsius.

Press the control panel heater button (6) to change to the desired temperature. There are 10 temperature settings. Reference the table for more detailed information.

After the temperature is selected will stay on for 10 seconds, then turn off.

Display Value	Temperature Setting
0	64°F/18°C
1	66°F/19°C
2	68°F/20°C
3	70°F/21°C
4	72°F/22°C
5	74°F/23°C
6	76°F/24°C
7	78°F/25°C
8	80°F/26°C
9	82°F/27°C
N	ON

### Adjusting the Ambient Side Lighting

Press the side light control button (4) to turn on the ambient lighting.

To change the colour of the lighting press the side light control button (4) again. You can control the side lights colour as described in the table. The colour rotation mode will cycle through the 3 different colour settings continuously.

Button Press	Ember Bed Color
1 <sup>st</sup> press	Blue
2 <sup>nd</sup> press	Amber
3 <sup>rd</sup> press	Amber and Blue
4 <sup>th</sup> press	Color Rotation
5 <sup>th</sup> press	OFF

### Using the Timer Control Button

Pressing the timer control button (3) will set the timer.

**NOTE: If this product experiences exceptionally high temperature, it may automatically stop heating. If this occurs the product should be unplugged or isolated from the main supply for a period of 30 seconds before the power is then re-supplied.**

Button Press	Timer Interval	Display Value
1 <sup>st</sup> press	1 Hour	1
2 <sup>nd</sup> press	2 Hour	2
3 <sup>rd</sup> press	3 Hour	3
4 <sup>th</sup> press	4 Hour	4
5 <sup>th</sup> press	5 Hour	5
6 <sup>th</sup> press	6 Hour	6
7 <sup>th</sup> press	7 Hour	7
8 <sup>th</sup> press	8 Hour	8
9 <sup>th</sup> press	OFF	NONE

### Manual ON/OFF switch

There is a manual ON/OFF switch is located on the right hand side of the appliance. This allows the user to turn the appliance on or off.

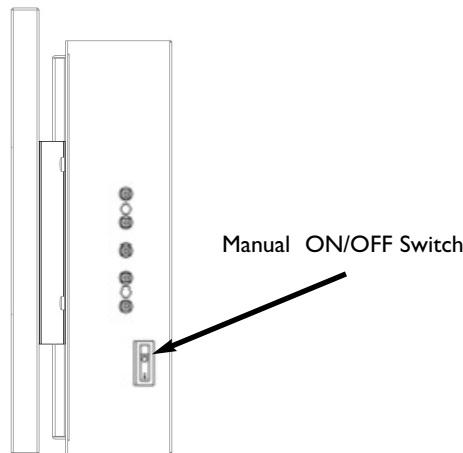

On the top right side plate of the firebox is the control panel. This panel contains the buttons to properly operate the electric fireplace. The buttons function are similar with that on the Remote Control, except if you want to adjusting the temperature, you need to press the button 5 for several seconds till the temperature indicator flash, then press the button 5 again to select the desired temperature.

- 1. Main Power Button
- 2. Flames Control Button
- 3. Timer Function Button
- 4. Side Light Control Button
- 5. Thermostat On/Off Button

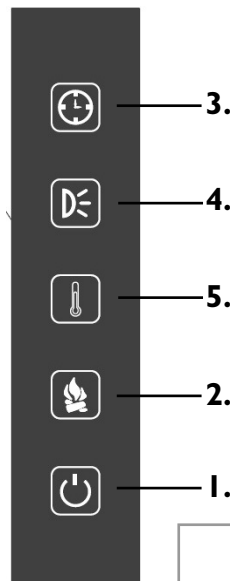

NOTE : Please use the handle when moving.

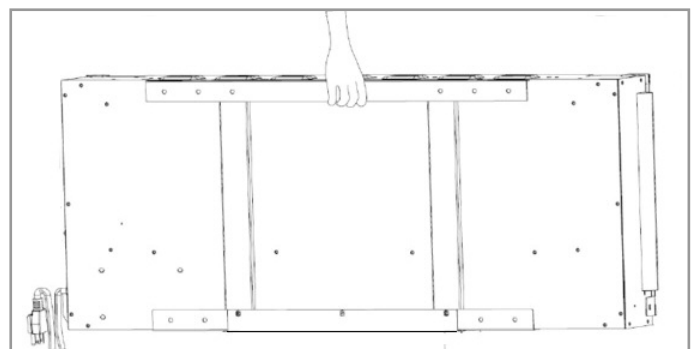

## 10.0 SAFETY CUTOUT SYSTEM

GB IE

This product has one non-self-resetting overheat protection device (thermal cut-out) which will activate if the air inlets or outlets are obstructed. For safety reasons the fire will NOT switch on again automatically, the following procedure must be carried out before the fire can be operated.

NOTE: The visual effect will remain operational if the cutout is activated, only the fan heater is prevented from working.

Switch OFF the appliance **at the wall socket or outlet**. Leave the fire OFF for a period of no less than 10 minutes, ensuring all obstructions are removed. Switch the appliance ON **at the wall**. Ensure the appliance is turned ON at the control switches. If the fire fails to operate correctly, repeat the above procedure. If an attempt to switch on the appliance is made before the safety cutout has reset, the appliance may cutout for a further period of time. If the sequence has been followed correctly and the appliance still fails to function, check the fuse in the wall outlet. If this is not the cause, call an electrician or maintenance engineer.

## 11.0 CLEANING AND MAINTENANCE

**ALWAYS DISCONNECT THE APPLIANCE FROM THE MAINS SUPPLY OUTLET SOCKET BEFORE UNDERTAKING ANY CLEANING OR MAINTENANCE!**

For general cleaning use a soft clean duster - never use harsh abrasive or cleaners. The glass viewing screen should be cleaned carefully with a soft cloth.

If in doubt consult a qualified electrician. Refer to Section 3.0 Appliance Data for fuse specification. Excluding fuses, use only genuine manufacturers spare parts available from your supplier.

### Replacing the remote control battery:

When the battery becomes weak, the range of the remote control becomes shorter. Replace the battery with a new CR2025 lithium battery.

Note: Keep the lithium battery out of the reach of children.

## 12.0 SERVICING

### There are no internal user serviceable parts.

Check regularly for security of wall fixings as appropriate. Also check security of supply cable and connections. If the supply cable becomes damaged, it must be replaced by a service agent or competent person, such as a qualified electrician.

This appliance is supplied with a BS1363 3 pin plug fitted with a 13 Amp fuse. Should the fuse require replacing, it must be replaced with a fuse rated at 13 Amp and approved to BS1362. In the event of the mains plug being removed/ replaced for any reason, please note : **IMPORTANT:** The wires in the mains lead are coloured in accordance with the following code:

Blue - Neutral

Brown - Live

Green/ Yellow - Earth

As the colours of the wires in the mains lead of this appliance may not correspond with the colour markings identifying the terminals in your plug, proceed as follows. The blue wire must be connected to the terminal marked with an N or coloured black. The brown wire must be connected to the terminal marked with an L or coloured red. The green/yellow wire must be connected to the earth terminal which is marked with an E or with the earth symbol. **WARNING:** Never connect live or neutral wires to the earth terminal of the plug.

NOTE: If a moulded plug is fitted and has to be removed take great care in disposing of the plug and severed cable, it must be destroyed to prevent engaging into a socket.

Refer to Section 3.0, Appliance Data for fuse specification. Excluding fuses, use only genuine manufacturers spare parts available from your supplier.

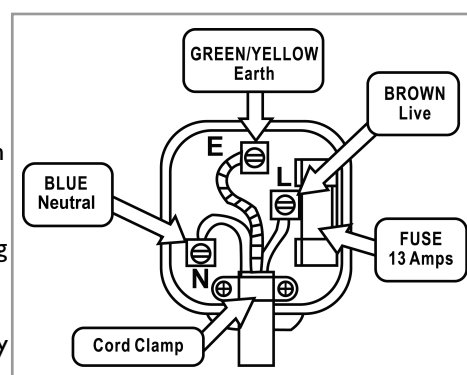

## 13.0 TROUBLESHOOTING GUIDE

GB IE

<b>Fire is not switching on</b>	Ensure mains switch is on Replace the fuse in the plug
<b>Fire is not emitting any heat</b>	The fire is fitted with an energy saving thermostat. If the temperature in the room is higher than the temperature selected on the fire, then the thermostat will stop the heater from turning on. For example, if the room temperature is 22°C or above and the fire's heater is set at 22°C, then the heater will not be required until the room temperature drops below 22°C. If this is the case select a higher temperature setting than the room's temperature and the heater will begin to operate.
<b>Fire shuts off after a period of time</b>	Check that the temperature is not set onto the lower settings. If the room is warm enough the thermostat will stop the fire switching the heat on. Check that the chimney/flue is blocked off.
<b>Fire seems noisy</b>	There is a level of noise when the flame effect is in use, caused by a motor that helps generate the effect. This noise will be heard when there is no other background noise. There is a higher level of noise associated with the heater motor; this is due to the air flow required when heat has been selected.
<b>Remote is not operating</b>	Check or replace batteries.

## 14.0 GUARANTEE - TERMS AND CONDITIONS

### Registration is not required.

Appliances purchased prior to 1st February 2009, and those specifically marked as '1 year guarantee' on this website, are guaranteed for one year from the date of purchase, provided that the following three terms and conditions are adhered to:

1. For any claim to be made within 1 year from date of purchase you will be required to provide and supply us with your original proof of purchase. 2. Your gas fire must have been commissioned by Gas Safe registered installer, evidence of which you must provide together with the registration number. 3. All appliances must have been installed and operated in accordance with the manufacturer's instructions.

### 3 Year Guarantee Terms and Conditions

Please be advised that the 3 year guarantee only covers products purchased on or after 1st February 2009.

The 3 year guarantee is only applicable to purchases made through an authorised stockist/retailer. Please see our website for a list of authorised stockists. Any purchase(s) made through an unauthorised stockist(s) will be eligible for a statutory 1 year guarantee.

For all gas fires purchased the 3 year guarantee commences from the date of purchase, provided that the following 4 terms and conditions are adhered to:

1. For any claim to be made within the 3 years from date of purchase you will be required to provide and supply us with your original proof of purchase. 2. Your gas fire must have been commissioned by Gas Safe registered installer, evidence of which you must provide together with the registration number. 3. Your appliance must have been serviced annually by Gas Safe registered installer, evidence of which must be provided, such as the receipt. 4. Purchase(s) must be made through an authorised stockist/retailer.

Please note all consumable items such as any ceramics including; coals, pebbles, the matrix, front strips, side cheeks, rear panels and tapered rear panels are not covered by the 3 year guarantee.

During the guarantee period any product or component which is proved to be faulty or defective in manufacture, will be repaired or replaced free of material and labour charges, providing that we have authorised or carried out the repair or replacement.

We will not accept or reimburse the costs of any third party who undertakes any work carried on the product or fits parts, unless we have approved such work in advance of it being carried out.

The guarantee period will not be extended even if we repair or replace any product or part.

For all electric fires purchased the 3 year guarantee commences from the date of purchase, providing that you can supply the proof of purchase. This does not cover consumable items such as pebbles, coals or light bulbs. Purchase(s) must be made through an authorised stockist.

### Making a claim:

Making a claim is easy. If you wish to make a claim under our guarantee and all the terms and conditions for your product have been met then please submit the following information for the attention of the 3G Service Department to the address below. Alternatively, you can email or fax. Superior Fires, 3G Service Department, Reid Street, Christchurch, Dorset, BH23 2BT. Email: [service@superiorfires.co.uk](mailto:service@superiorfires.co.uk), Fax: 01202 499326.

### Details required:

1. Name, full address including postal code and contact telephone number.
2. A copy of your proof of purchase e.g. receipt or bank statement.
3. Original installers Gas Safe registration number (gas fires only).
4. Annual service receipt for every 12 months (gas fires only).

Please note that this does not affect your statutory rights.

 Waste electrical products should not be disposed of with household waste. Please recycle where facilities exist. Check with your local authority or retailer for recycling advice.  
As our policy is one of continuous improvement and development, we therefore hope that you will understand we must retain the right to amend details and/or specifications without prior notice.